

TOSHIBA



“ Do you want a versatile solution to make significant savings? ”



ESTIA



TOSHIBA AIR CONDITIONING > RESIDENTIAL HEATING > AIR-TO-WATER HEAT PUMP > **ESTIA**

**whatever
you need**

ON YOUR OWN AS A FAMILY IN A GROUP ON YOUR OWN



Surpassing well-being

Following European commitments to reduce emissions by 20% by 2020, energy waste from residential heating and domestic hot water has been identified as a possible reduction target. Air-to-water heat pumps are classed as a form of renewable energy technology, contrary to heating systems that rely on fossil fuels or inefficient electrical heating.

They are now considered to be ideal solutions for space heating and domestic hot water. Residential heat production using gas, oil or electricity increases atmospheric CO² emissions levels. In addition, these traditional heating systems are less efficient and therefore have higher running and maintenance costs. Toshiba Estía air-to-water heat pumps are the ideal solution for increasing energy efficiency, using air as its main source of energy. This all-in-one system is designed to ensure that the right temperature for space heating and domestic sanitary hot water is achieved quickly and efficiently, with the additional advantage of also functioning as a cooling source, in the warmer seasons.

**> RESIDENTIAL
AIR TO WATER**

AS A FAMILY IN A GROUP ON YOUR OWN AS A FAMILY



ESTIA SPLIT



4 to 16 kW



> ESTIA SPLIT

OUTDOOR UNITS

Toshiba has long-term experience of successes in air-to-air heat pump production. The same reliable and award-winning technology is at the core of the new air-to-water heat pumps, above all the advanced inverter technology and the DC twin-rotary compressor. ESTIA heat pumps operate with the reliable and safe R410A refrigerant.



HOT WATER TANK

The ESTIA tank is a compact stainless steel insulated tank producing domestic hot water for sanitary use.

The performance of the overall system is also maximised thanks to the integrated coaxial heat exchanger.

The internal electric heater is controlled to optimise the use of the system in the case of extreme outdoor air temperatures. This solution reduces running costs and guarantees a constant hot water temperature inside the tank.



HYDRO UNITS

The high-efficiency plate heat exchanger produces hot water at low or medium temperature (35-60°C) or cold water (7-20°C). A back-up heater (3.6 or 9 kW options) further supports the operation for extreme conditions. The hydro unit integrates the advanced control of water temperature to allow an optimized distribution to emitters and to the domestic hot water tank.

CONTROLLER 2 zones with weekly timer



The large screen remote controller is designed to be simple, intuitive and easy to use.

The remote controller allows independent heating to a maximum of 2 zones and domestic hot water.

It regulates the water temperature and optimises the systems energy consumption. The anti-bacteria control and the hot water boost functions can easily be activated.

The remote controller can also be used to set weekly timers for the system and, when used as a second remote controller, can be used to control room air temperature.

Leading energy efficiency A++/A++ with COP 3.01 @ -7°C outdoor air, water 35°C

With its best-in-class COP performance, the ESTIA air-to-water heat pump system delivers more heating power with less energy consumption. With the Toshiba advanced inverter, Estia air-to-water heat pump system only delivers the heating capacity required, thus reducing the amount of electricity used and the running costs of the heating system.

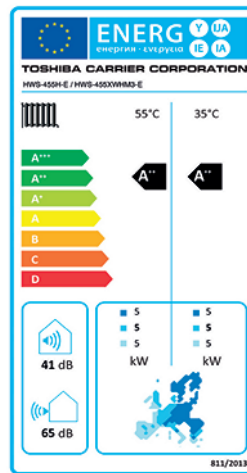

ESTIA Space Heating Energy Label

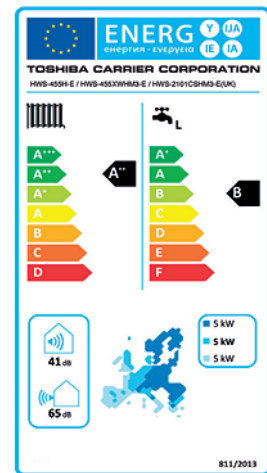

ESTIA combination & heater (with Domestic Hot Water) Energy Label

ESTIA DOMESTIC HOT WATER HEAT PUMP

The best energy savings for sanitary hot water production throughout the year

Toshiba DHW-HP is providing best in class performances on the market with:

- A+ Energy Label Class
- High COP 3.69 according to EN16147
- Very low noise level and Silent function
- Variable air flow rate & high ESP fan up to 200 Pa
- Hot water production up to 65°C

The Toshiba DHW-HP provides 80% energy savings Vs traditional electric water heaters with best in class COP 3.69 (EN16147 LCIE certified). Compatible with solar systems (photovoltaic panels ready or solar built-in extra coil), and smart grid ready, makes it the best solution for increased energy savings.

The innovative and adaptive controller is user friendly with 5 operational modes AUTO, ECO, BOOST, SILENT and HOLIDAY.

Toshiba DHW-HP offers flexible control solutions with low electricity tariff mode, energy consumption display, Smart grid ready, Modbus connectivity, Air Cooling function & Floor Heating function with extra coil.

Toshiba DHW-HP is particularly reliable thanks to its anti-corrosion enamelled steel tank with magnesium anode.

The electrical heater back-up provides hot water at any time.



ONE SYSTEM,
FULL COMBINATIONS FLEXIBILITY

For new houses or refurbishment projects ESTIA heat pumps offer a variety of combinations. Some examples are shown below:

1 Space heating with domestic hot water

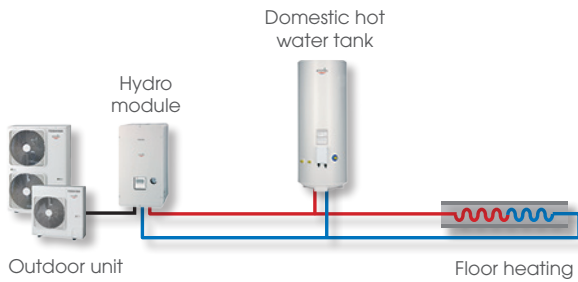

1 Space heating/cooling with domestic hot water

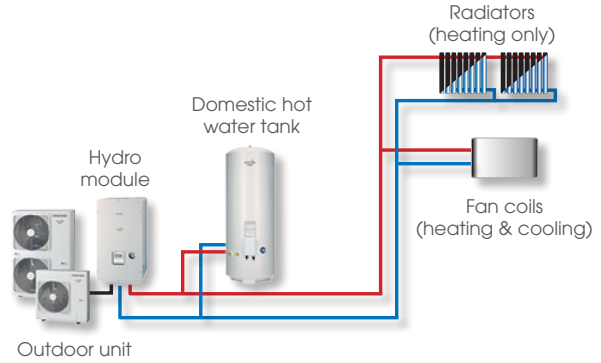

2 Space heating with domestic hot water

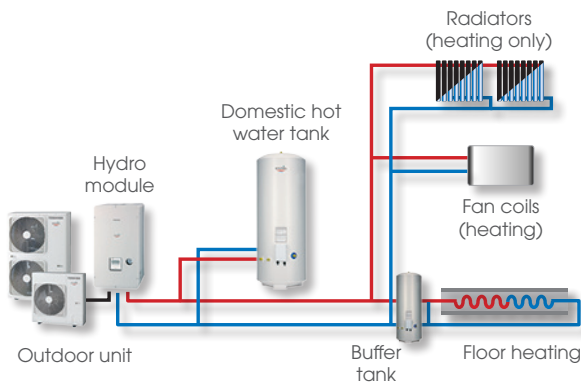

2 Space heating with domestic hot water & backup boiler

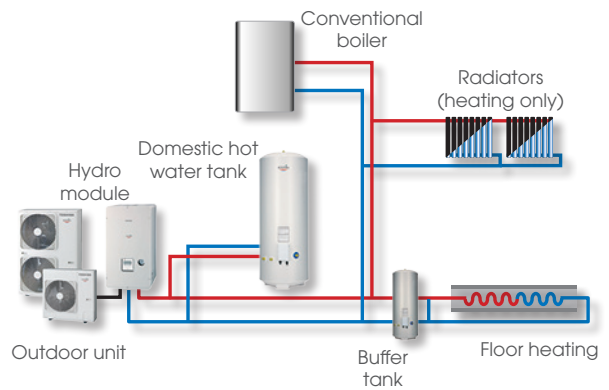

2 Space heating/cooling (multiple zones) with domestic hot water & solar panels

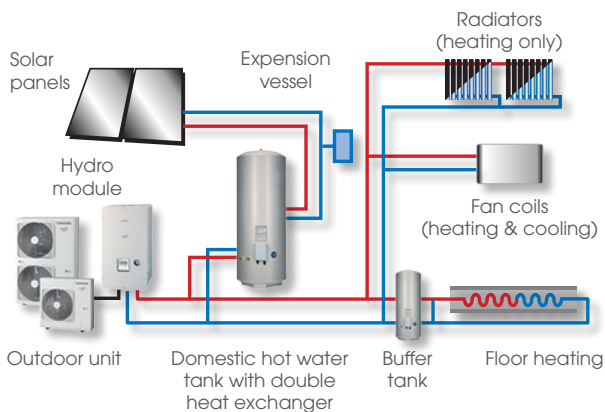

2 Space heating/cooling (multiple zones) with domestic hot water

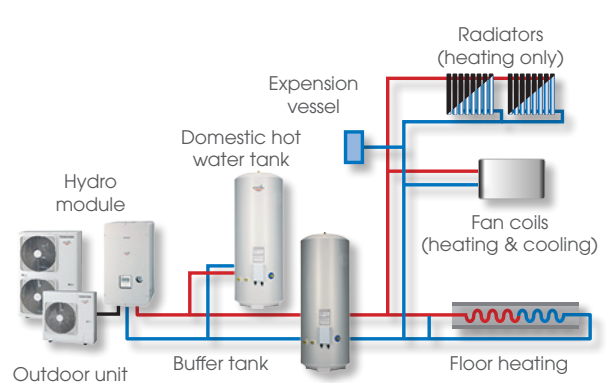

In existing dwellings already equipped with traditional gas or fuel boilers, the Toshiba ESTIA air-to-water heat pump system can be combined with the existing heating system to fully cover and optimise all heating needs, all year round. The boiler is then only used as a back-up source during some extreme weather days during the winter. The intelligent Toshiba control balances the energy source in the most efficient way.

Toshiba offers different control solutions to meet end users' and designers' expectations. From local individual control and settings to computer-based TCC-Link network, all indoor units can be programmed and set to suit the operational needs. Remote control systems offer a wide range of features including schedule timers, diagnostic functions, input/output signals, to name a few.

Toshiba offers a number of local control products that can be used to control a single indoor unit, or group of up to 8 indoor units, from a position adjacent to that indoor unit or group. It is possible to install these local controllers up to 500 m from the connected indoor unit which allows greater flexibility when designing the installation site.

2 Zone & 2 water pump control

Space heating/cooling (multiple zones) with domestic hot water.

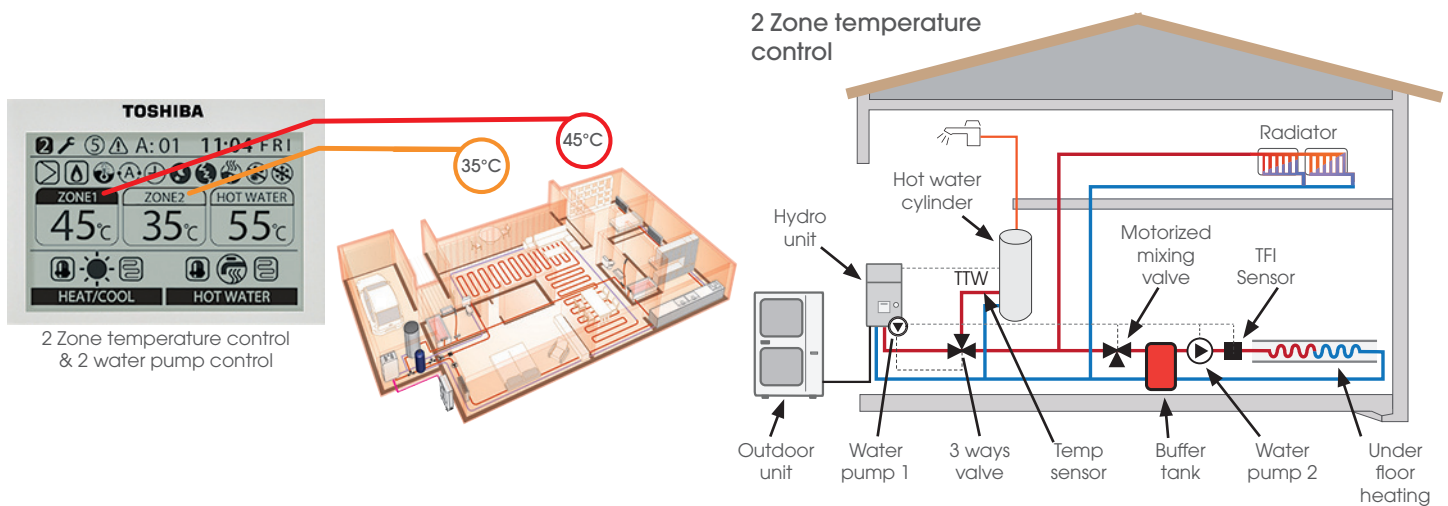

Control integration

ESTIA Master/Slave group control function allows up to 2 remote controllers to operate simultaneously up to 8 systems. ESTIA Open protocol interfaces Modbus & KNX are available in Home Energy Management Systems.

Group control function

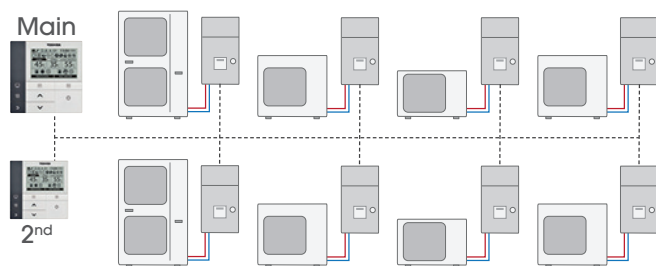

One remote controller can operate simultaneously up to 8 systems

Note: Maximum connections configuration: 8 outdoors and 2 remote controllers

Open protocol interfaces

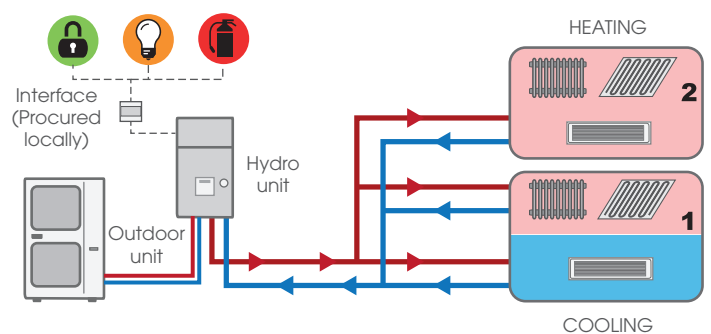

Modbus and KNX interfaces are available to use in Home Energy Management Systems

HWS_XWH
ESTIA SPLIT S5



The Toshiba air to water heat pump split system is designed to deliver the right temperature for space heating and produce domestic sanitary hot water throughout the year. The ESTIA system has the additional advantage of providing cooling in the warmer seasons.

High Energy efficiency providing enhanced energy savings

A++ / A++ energy class in space heating & combination heater. Part Load efficiency η_s up to 163% according to EF14511 & EN14825.

The Toshiba Inverter uses the new vector controlled Intelligent Power Drive Unit, which enables a wider range of compressor frequencies resulting in better temperature control.

Easy to install, easy to control

Quick and easy to install, the ESTIA hydro module unit can be placed safely in the most suitable place within the house.

Its large screen remote controller is designed to be simple, intuitive and easy to use. ESTIA is compatible with latest generations of connected thermostat.

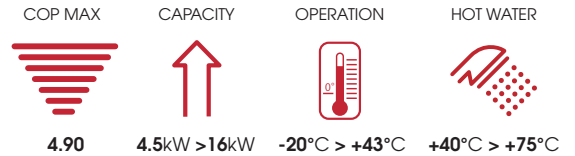

Best in class performances:

- > Max COP 4.90 @+7°C & 3.08 @-7°C air temperature
- > Heating operation down to -20°C
- > Domestic sanitary hot water +40°C to +75°C
- > Master/Slave group control up to 8 units



011-1W0341 → 0348



INDOOR UNITS

- HWS-455XWHM3-E
- HWS-805XWHM3-E
- HWS-805XWHT6-E
- HWS-1405XWHM3-E
- HWS-1405XWHT6-E
- HWS-1405XWHT9-E



OUTDOOR UNITS

- HWS-455H-E
- HWS-805H-E
- HWS-1105H-E
- HWS-1405H-E
- HWS-1105H8-E
- HWS-1405H8-E
- HWS-1605H8-E



REMOTE CONTROLS

- HWS-AMS54E



DOMESTIC HOT WATER TANK

- HWS-1501CSHM3-E
- HWS-2101CSHM3-E
- HWS-3001CSHM3-E

ESTIA SPLIT S5

ESTIA SPLIT S5 Performance data

Outdoor unit			HWS-	455H-E	805H-E	1105H-E	1105H8(R)-E	1405H-E	1405H8(R)-E	1605H8(R)-E	
Hydro unit combination	Air T°	Water T°	HWS-	455XWHM3-E	805XWH**E	1405XWH**E	1405XWH**E	1405XWH**E	1405XWH**E	1405XWH**E	
Under floor heating	Max heating capacity	+7°C 35°C	kW	H 6.83	8.52	14.63	16.74	14.73	15.77	16.76	
	Nominal heating capacity	+7°C 35°C	kW	H 4.5	7.51	10.52	10.52	13.15	13.15	14.91	
	COP	+7°C 35°C	W/W	H 4.9	4.46	4.88	4.8	4.5	4.44	4.3	
	Energy Efficiency Class - Low Temp (Ecodesign LOT1-2015)		35°C	H	A++	A++	A++	A++	A++	A++	A++
	Energy Efficiency Class - Low Temp (Ecodesign LOT1-Sept2019)		35°C	H	A++	A++	A++	A++	A++	A++	A++
	Seasonal space heating energy efficiency (ηs)		35°C	H	167%	161%	163%	161%	159%	157%	159%
	Seasonal space heating energy efficiency (SCOP)		35°C	H	4.28	4.12	4.17	4.12	4.08	4.02	4.07
	Max heating capacity	-7°C 35°C	kW	H 4.48	5.74	9.67	9.50	10.79	10.64	11.25	
	Heating capacity ⁽¹⁾	-7°C 35°C	kW	H 4.18	5.00	8.04	8.04	8.63	8.64	9.05	
	COP	-7°C 35°C	W/W	H 3.01	2.7	2.78	2.79	2.62	2.76	2.67	
	Max heating capacity	-15°C 35°C	kW	H 3.61	4.47	7.52	7.29	8.34	8.16	8.63	
	Heating capacity ⁽¹⁾	-15°C 35°C	kW	H 3.14	4.02	6.17	6.38	6.86	6.85	7.18	
COP	-15°C 35°C	W/W	H 2.45	2.68	2.5	2.63	2.6	2.6	2.52		
Radiators heating & DHW	Max heating capacity	+7°C 45°C	kW	H 6.42	8.13	13.62	14.26	13.93	15.07	15.77	
	Max heating capacity	-7°C 45°C	kW	H 4.37	5.55	9.16	9.59	9.17	10.12	10.64	
	Max heating capacity	-15°C 45°C	kW	H 2.84	4.31	7.12	7.03	7.37	7.75	8.15	
	Max heating capacity	+7°C 55°C	kW	H 6.25	7.93	10.98	11.67	12.56	13.64	14.12	
	Max heating capacity	-7°C 55°C	kW	H 4.29	5.29	8.83	8.93	8.92	9.76	10.22	
	Energy Efficiency Class - Medium Temp (Ecodesign LOT1-2015)		55°C	H	A++	A++	A++	A++	A++	A++	
	Energy Efficiency Class - Low Temp (Ecodesign LOT1-Sept 2019)		55°C	H	A++	A++	A++	A++	A++	A++	
	Seasonal space heating energy efficiency (ηs)		55°C	H	125%	127%	130%	130%	129%	129%	130%
	Seasonal space heating energy efficiency (SCOP)		55°C	H	3.22	3.27	3.35	3.34	3.31	3.31	3.33
	Cooling	Nominal cooling capacity	35°C 7°C	kW	C 4.5	6	10	10	11	11	13
EER			W/W	C 3.08	3.1	3.07	3.07	2.89	2.89	2.71	

Max heating capacities are shown at peak value during operation, at max compressor operating range in accordance with EN14511
 Nominal heating capacity are given at water delta T° 5°C and rated compressor operating frequency in accordance with EN14511
 (1) Heating capacity at -7°C are shown at max compressor operating frequency in accordance with EN14511
 Energy Efficiencies Class & Seasonal space heating energy efficiency (ηs) are provided for Average Climate conditions in accordance with EN14825

ESTIA SPLIT S5 Physical data outdoor unit

Outdoor unit		HWS-	455H-E	805H-E	1105H-E	1105H8-E	1405H-E	1405H8-E	1605H8-E
Dimensions (HxWxD)	mm		630x800x300	890x900x320	1340x900x320	1340x900x320	1340x900x320	1340x900x320	1340x900x320
Weight	kg		42	63	92	93	92	93	93
Sound pressure level (max) ⁽²⁾	dB(A)		49	50	51	51	52	52	53
Sound power level (max)	dB(A)		65	66	66	66	68	68	69
Compressor type			DC Twin rotary	DC Twin rotary	DC Twin rotary	DC Twin rotary	DC Twin rotary	DC Twin rotary	DC Twin rotary
Refrigerant type			R410A	R410A	R410A	R410A	R410A	R410A	R410A
Refrigerant charge	kg		1.15	1.80	2.70	2.70	2.70	2.70	2.70
Flare connections (gas-liquid)			4/8" - 2/8"	5/8" - 3/8"	5/8" - 3/8"	5/8" - 3/8"	5/8" - 3/8"	5/8" - 3/8"	5/8" - 3/8"
Minimum pipe length	m		5	5	5	5	5	5	5
Maximum pipe length	m		15	30	30	30	30	30	30
Maximum height difference	m		10	30	30	30	30	30	30
Chargeless pipe length	m		15	30	30	30	30	30	30
Operating range in space heating*	°C		-20-25	-20-25	-20-25	-20-25	-20-25	-20-25	-20-25
Operating range domestic hot water	°C		-20-43	-20-43	-20-43	-20-43	-20-43	-20-43	-20-43
Operating range in cooling	°C		10-43	10-43	10-43	10-43	10-43	10-43	10-43
Bottom tape heater power	W		-	-	-	75	-	75	75
Power supply	V-ph-Hz		220/230-1-50	220/230-1-50	220/230-1-50	380/400-3N-50	220-230-1-50	380/400-3N-50	380/400-3N-50

* Depending on the conditions only back-up heater operates. ** Heater Operation in more than 35°C
 (2) Measurement position : Front = 1m, Height = 1.5m

ESTIA SPLIT S5 Physical data hydro unit

Hydro unit		HWS-	455XWHM3-E	805XWHM3-E	805XWHT6-E	805XWHT9-E	1405XWHM3-E	1405XWHT6-E	1405XWHT9-E
To be used with size			45	80	80	80	110-140-160	110-140-160	110-140-160
Leaving water temperature	°C	H	20-55°C	20-55°C	20-55°C	20-55°C	20-55°C	20-55°C	20-55°C
Leaving water temperature	°C	C	7-25°C	7-25°C	7-25°C	7-25°C	7-25°C	7-25°C	7-25°C
Dimensions (HxWxD)	mm		925x525x355	925x525x355	925x525x355	925x525x355	925x525x355	925x525x355	925x525x355
Weight	Kg		49	49	49	49	52	52	52
Sound pressure level	dB(A)		29	29	29	29	32	32	32
Sound power level	dB(A)		41	41	41	41	43	43	43
Electric back up heater capacity	kW		3	3	6	9	3	6	9
Electric back up heater supply	V-ph-Hz		220-230-1-50	220-230-1-50	380-400-3N-50	380-400-3N-50	220-230-1-50	380-400-3N-50	380-400-3N-50
Maximum current	A		13	13	13 x 2	13 x 3	13	13 x 2	13 x 3

ESTIA SPLIT S5 Physical data sanitary hot water tank

Domestic hot water tank		HWS-	1501CSHM3-E	2101CSHM3-E	3001CSHM3-E
Water volume	litres		150	210	300
Max water temperature	°C		75	75	75
Electric heater	kW		2.7	2.7	2.7
Power supply	V-ph-Hz		220/230-1-50	220/230-1-50	220/230-1-50
Height	mm		1 090	1 474	2 040
Diameter	mm		550	550	550
Weight	Kg		31	41	60
Material			Stainless steel	Stainless steel	Stainless steel

ACCESSORIES

Model name	Description	Functions
TCB-PCIN3E	Output signal PCB	Boiler operation output signal. Alarm output signal. Defrost output signal. Compressor operation output signal
TCB-PCMO3E	Input signal PCB	Room thermostat input. Emergency stop input
HWS-AMS54E	Wired RC	Wired Remote controller(sub)

HWS-(P)_XWH
ESTIA SPLIT S5 POWERFUL



The Toshiba air to water heat pump split system is designed to deliver the right temperature for space heating and produce domestic sanitary hot water throughout the year. The ESTIA system has the additional advantage of providing cooling in the warmer seasons.

High Energy efficiency providing enhanced energy savings





A++ / A++ energy class in space heating & combination heater. Part Load efficiency ηs up to 175% according to EF14511 & EN14825.

The Toshiba Inverter uses the new vector controlled Intelligent Power Drive Unit, which enables a wider range of compressor frequencies resulting in better temperature control.

Easy to install, easy to control

Quick and easy to install, the ESTIA hydro module unit can be placed safely in the most suitable place within the house.

Its large screen remote controller is designed to be simple, intuitive and easy to use. ESTIA is also compatible with latest generations of connected thermostat.

COP MAX  4.88	CAPACITY  16kW >18kW	OPERATION  -25°C > +43°C	HOT WATER  +40°C > +75°C
--	---	---	---

Best in class performances:

- > Max **COP 4.88 @+7°C & COP 2.67 @-7°C** air temperature
- > **Maintain rated capacity down to -15°C**
- > Heating operation down to **-25°C**
- > Domestic sanitary hot water **+40°C to +75°C**
- > Master/Slave group control up to 8 units



R410A
 with TOSHIBA



011-1W0341 → 0348



INDOOR UNITS

- HWS-P805XWHM3-E
- HWS-P805XWHT6-E
- HWS-P805XWHT9-E
- HWS-P1105XWHM3-E
- HWS-P1105XWHT6-E
- HWS-P1105XWHT9-E



OUTDOOR UNITS

- HWS-P805H8R-E
- HWS-P1105H8R-E
- HWS-P1405H8R-E
- HWS-P805HR-E
- HWS-P1105HR-E



REMOTE CONTROLS

- HWS-AMS54E



HOT WATER TANK

- HWS-1501CSHM3-E
- HWS-2101CSHM3-E
- HWS-3001CSHM3-E

ESTIA SPLIT S5 POWERFUL

ESTIA SPLIT S5 POWERFUL Performance data

Outdoor unit			HWS-	P805HR-E	P1105HR-E	P805H8R-E	P1105H8R-E	P1405H8R-E		
Hydro unit combination	Air T°	Water T°	HWS-	P805XWH**E	P1105XWH**E	P805XWH**E	P1105XWH**E	P1105XWH**E		
Under floor heating	Max heating capacity	+7°C	35°C	kW	H	16.92	18.05	14.67	14.95	15.1
	Nominal heating capacity	+7°C	35°C	kW	H	8.00	11.20	8.00	11.20	14.00
	COP	+7°C	35°C	W/W	H	4.76	4.88	4.68	4.8	4.44
	Energy Efficiency Class - Low Temp (Ecodesign LOT1-2015)		35°C		H	A++	A++	A++	A++	A++
	Energy Efficiency Class - Low Temp (Ecodesign LOT1-Sept2019)		35°C			A++	A+++	A++	A++	A++
	Seasonal space heating energy efficiency (ηs)		35°C		H	157%	175%	169%	173%	173%
	Seasonal space heating energy efficiency (SCOP)		35°C		H	4.01	4.48	4.31	4.43	4.43
	Max heating capacity	-7°C	35°C	kW	H	11.92	12.79	10.82	11.62	13.44
	Heating capacity ⁽¹⁾	-7°C	35°C	kW	H	9.38	9.74	9.45	10.3	12.21
	COP	-7°C	35°C	W/W	H	2.67	2.64	2.81	2.39	2.53
	Max heating capacity	-15°C	35°C	kW	H	9.37	11.23	8.18	9.26	10.7
	Heating capacity ⁽¹⁾	-15°C	35°C	kW	H	7.26	8.06	7.77	8.75	8.91
	COP	-15°C	35°C	W/W	H	2.18	2.18	2.33	2.26	2.05
	Radiators heating & DHW	Max heating capacity	+7°C	45°C	kW	H	14.00	14.74	16.32	15.32
Max heating capacity		-7°C	45°C	kW	H	10.16	10.61	9.08	10.01	11.43
Max heating capacity		-15°C	45°C	kW	H	8.04	8.13	6.82	7.71	7.96
Max heating capacity		-20°C	45°C	kW	H	6.72	7.64	5.98	7.80	8.05
Max heating capacity		+7°C	55°C	kW	H	11.08	11.43	15.04	15.69	16.97
Max heating capacity		-7°C	55°C	kW	H	8.40	8.42	9.41	10.93	12.37
Energy Efficiency Class - Medium Temp (Ecodesign LOT1-2015)			55°C		H	A++	A++	A+	A++	A++
Energy Efficiency Class - Low Temp (Ecodesign LOT1-Sept 2019)			55°C			A++	A++	A+	A++	A++
Seasonal space heating energy efficiency (ηs)			55°C		H	125%	131%	123%	130%	130%
Seasonal space heating energy efficiency (SCOP)			55°C		H	3.22	3.38	3.16	3.35	3.34
Cooling	Nominal cooling capacity	35°C	7°C	kW	C	3.22	3.38	3.16	3.35	3.34
	EER			W/W	C	3.66	3.00	3.66	3.00	2.82

Max heating capacities are shown at peak value during operation, at max compressor operating range in accordance with EN14511
 Nominal heating capacity are given at water delta T° 5°C and rated compressor operating frequency in accordance with EN14511
 (1) Heating capacity at -7°C are shown at max compressor operating frequency in accordance with EN14511
 Energy Efficiencies Class & Seasonal space heating energy efficiency (ηs) are provided for Average Climate conditions in accordance with EN14825

ESTIA SPLIT S5 POWERFUL Physical data outdoor unit

Outdoor unit		HWS-	P805HR-E	P1105HR-E	P805H8R-E	P1105H8R-E	P1405H8R-E
Dimensions (HxWxD)	mm		1340x900x320	1340x900x320	1340x900x320	1340x900x320	1340x900x320
Weight	kg		92	92	94	94	94
Sound pressure level (max) ⁽²⁾	dB(A)		51	51	52	52	53
Sound power level (max)	dB(A)		66	66	66	67	68
Compressor type			DC Twin rotary	DC Twin rotary	DC Twin rotary	DC Twin rotary	DC Twin rotary
Refrigerant			R410A	R410A	R410A	R410A	R410A
Refrigerant charge	kg		2.70	2.70	2.70	2.70	2.70
Flare connections (gas-liquid)			5/8" - 3/8"	5/8" - 3/8"	5/8" - 3/8"	5/8" - 3/8"	5/8" - 3/8"
Minimum pipe length	m		5	5	5	5	5
Maximum pipe length	m		30	30	30	30	30
Maximum height difference	m		30	30	30	30	30
Chargeless pipe length	m		30	30	30	30	30
Operating range in space heating*	°C		-25-25	-25-25	-25-25	-25-25	-25-25
Operating range domestic hot water	°C		-25-43**	-25-43**	-25-43**	-25-43**	-25-43**
Operating range in cooling	°C		10-43	10-43	10-43	10-43	10-43
Bottom tape heater power	W		75	75	75	75	75
Power supply	V-ph-Hz		220/230-1-50	220/230-1-50	380/400-3-50	380/400-3-50	380/400-3-50

* Depending on the conditions only back-up heater operates. ** Heater Operation in more than 35°C.
 (2) Measurement position : Front = 1m, Height = 1.5m

ESTIA SPLIT S5 POWERFUL Physical data hydro unit

Hydro unit		HWS-	P805XWHM3-E	P805XWHT6-E	P805XWHT9-E	P1105XWHM3-E	P1105XWHT6-E	P1105XWHT9-E
To be used with size			80	80	80	110	110	110
Leaving water temperature (heating)	°C	H	20-60°C	20-60°C	20-60°C	20-60°C	20-60°C	20-60°C
Leaving water temperature (cooling)	°C	C	7-25°C	7-25°C	7-25°C	7-25°C	7-25°C	7-25°C
Dimensions (HxWxD)	mm		925x525x355	925x525x355	925x525x355	925x525x355	925x525x355	925x525x355
Weight	Kg		49**	49**	49**	52**	52**	52**
Sound pressure level	dB(A)		29	29	29	32	32	32
Sound power level	dB(A)		41	41	41	43	43	43
Electric back up heater capacity	kW		3	6	9	3	6	9
Electric back up heater supply	V-ph-Hz		220-230-1-50	380-400-3N-50	380-400-3N-50	220-230-1-50	380-400-3N-50	380-400-3N-50
Maximum current	A		13	13 x 2	13 x 3	13	13 x 2	13 x 3

ESTIA SPLIT S5 POWERFUL Physical data sanitary hot water tank

Domestic hot water tank		HWS-	1501CSHM3-E	2101CSHM3-E	3001CSHM3-E
Water volume	litres		150	210	300
Max water temperature	°C		75	75	75
Electric heater	kW		2.7	2.7	2.7
Power supply	V-ph-Hz		220/230-1-50	220/230-1-50	220/230-1-50
Height	mm		1 090	1 474	2 040
Diameter	mm		550	550	550
Weight	Kg		31	41	60
Cylinder Material			Stainless steel	Stainless steel	Stainless steel

ACCESSORIES

Model name	Description	Functions
TCB-PCIN3E	Output signal PCB	Boiler operation output signal, Alarm output signal, Defrost output signal, Compressor operation output signal
TCB-PCMO3E	Input signal PCB	Room thermostat input, Emergency stop input
HWS-AMS54E	Wired RC	Wired Remote controller(sub)



HWS-G_CNMRE
ESTIA DOMESTIC HOT WATER HEAT PUMP



The Toshiba DHW-HP is designed to provide the customer with best in class performance and energy savings, for sanitary hot water production, throughout the year. Thanks to its large operating range, high external static pressure fan and low noise operation the Toshiba DHW-HP is suitable for all types of installation.

Comfort & ease of installation

- Sanitary hot water can be produced throughout the year, using only the heat pump, thanks to the innovative design of the unit and the large operating temperature range (Air -7°C to +40°C). Installation is simplified due to the slimline chassis design (Ø603mm) and easy access to water pipe connections.

Highest efficiency for best energy savings

- The Toshiba DHW-HP provides 80% energy savings Vs traditional electric water heaters with best in class COP 3.69 (EN16147 LCIE certified). Compatible with solar systems (photovoltaic panels ready or solar built-in extra coil), and smart grid ready, makes it the best solution for increased energy savings.

Innovative & reliable

- Anti-corrosion protection with enamelled steel tank and magnesium anode. Back-up electrical heater to secure hot water production at any time.

Intuitive & adaptive control

- User friendly control with 5 operational modes AUTO, ECO, BOOST, SILENT and HOLIDAY. Flexible control solutions: Low electricity tariff mode, energy consumption display, Modbus connectivity, Air Cooling function & Floor Heating function with extra coil.

COP MAX	OPERATION	HOT WATER
3.69	-7°C > +40°C	Up to 65°C

Best in class performances:

- > Energy class A+ (ErP 2017)
- > Heat pump hot water production from -7°C to +40°C outside air temperature
- > Hot water temperature to 60°C without the use of electric heaters
- > Adjustable airflow rate (0-800m³/h)
- > Best in class fan external static pressure (up to 200Pa)
- > Low noise operation
- > Slimline chassis design (Ø603mm)
- > Flexible control options including Modbus connectivity
- > Compatible with other renewable technologies solar thermal and solar photovoltaic (advanced option only)
- > Smart Grid Ready (advanced option only)



DHW-HP UNITS

HWS-G190
 HWS-G260



REMOTE CONTROLS

DHW-HP
 Control panel

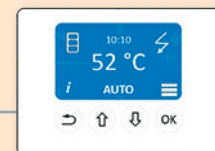

ESTIA DOMESTIC HOT WATER HEAT PUMP

ESTIA DOMESTIC HOT WATER HEAT PUMP Performance data

Domestic Hot Water Heat Pump		HWS-G1901CNMR-E	HWS-G2601CNMR-E
Energy Class	Label	A+	A+
η_{WH}	%	146	150
COP at Air7°C W10°C-52,9°C (EN16147)		3,57	3,69
COP at Air15°C W10°C-52,9°C (EN16147)		3,90	3,87
Heat pump operating range (min/max)	°C	-7 / +40	-7 / +40
Heat up time (A7°C W10°C-53,5°C)	hr:mm	06:27	09:12
Maximum quantity of usable hot water Vmax 40 volume (W52.9°C)	liters	247	347
Cylinder volume	liters	190	260
Cylinder profile		L	XL
Maximum water temperature (heat pump & elect.heater)	°C	65	65
Maximum water temperature (heat pump only)	°C	60	60
Corrosion protection		Magnesium anode	Magnesium anode
Noise power level - Ducted (ISO12102)	dB(A)	49.0	49.0
Noise pressure level @2m - Ducted	dB(A)	32.0	32.0
Noise power level - Non ducted (ISO12102)	dB(A)	55.6	55.6
Noise pressure level @2m - Non ducted	dB(A)	38.6	38.6
Airflow rate nominal (min - max)	m³/h	450 (0 - 800)	450 (0 - 800)
Maximum fan power	W	85	85
Maximum external static pressure	Pa	200	200
Air duct connections	mm	160	160
Minimum room volume (non ducted unit)	m³	60	60
Maximum power input	W	2185	2185
Electrical heater power	W	1500	1500
Maximum compressor power	W	600	600
Auxiliary power input (Paux)	W	1.61	1.61
Standby power input (Pes)	W	17	20

ESTIA DOMESTIC HOT WATER HEAT PUMP Physical data

Domestic Hot Water Heat Pump		HWS-G1901CNMR-E	HWS-G2601CNMR-E
Dimensions (Height x Diameter)	mm	1600 x 620	1600 x 620
Required height for installation	mm	1868	2223
Weight (dry / wet)	kg	94 / 284	100/350
Refrigerant		R134A	R134A
Refrigerant charge	kg	1.2	1.28
Refrigerant charge CO₂ equivalent	ton	1.72	1.83
Water connections (cold & hot water)	inch	3/4	3/4
Standard water connection entry angle	deg.	45	45
Condensates water connections	mm	Diam19	Diam19
Max water side operating pressure	Mpa	0.6	0.6
Power supply	V-ph-Hz	230-1-50	230-1-50

(1) Sound pressure calculation based on spherical sound propagation and infinite room (directivity factor Q=1)

ESTIA DOMESTIC HOT WATER HEAT PUMP Product configurations

Description	Model name	Functions
190l cylinder + 180°C variant water connection position	HWS-G1901CNRR-E	Alternative water connection entry position for flexible installation
190l cylinder + deluxe PCB	HWS-G1901CNXR-E	Deluxe PCB option allowing connection of: - Solar Photovoltaic - Smart Grid Ready - Additional pump / ventilation damper
190l cylinder + deluxe PCB + heating coil	HWS-G1901ENXR-E	All of the features of the deluxe PCB option with the additional benefit of connection to a solar thermal system
260l cylinder + 180°C variant water connection position	HWS-G2601CNRR-E	Alternative water connection entry position for flexible installation
260l cylinder + deluxe PCB	HWS-G2601CNXR-E	Deluxe PCB option allowing connection of: - Solar Photovoltaic - Smart Grid Ready - Additional pump / ventilation damper
260l cylinder + deluxe PCB + heating coil	HWS-G2601ENXR-E	All of the features of the deluxe PCB option with the additional benefit of connection to a solar thermal system